

# Meterkast van de Toekomst

THUAS Delft, The Netherlands

P.J. van Duijsen



[www.caspoc.com](http://www.caspoc.com)

November 19 , 2024

## Meterkast van de toekomst

- 1 Opwek en Verbruik
- 2 Verbruiksprofielen huishouden
- 3 Congestie Management
- 4 Conclusions

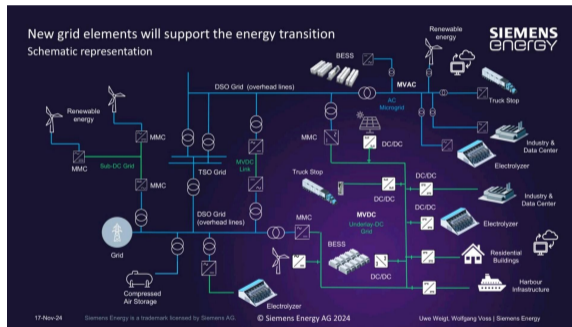

Figure courtesy of Siemens©2024

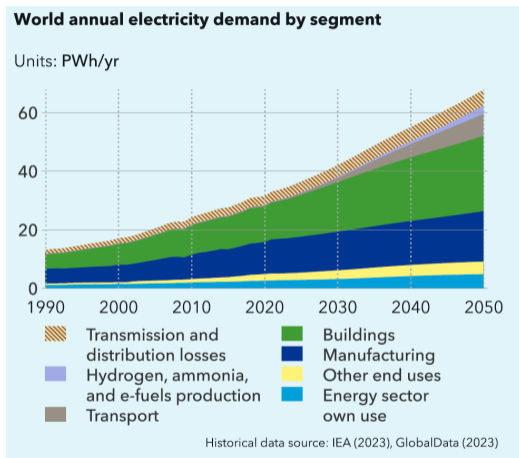

Figure courtesy of DNV©2024

## World grid-connected electricity generation by power station type

Units: PWh/yr

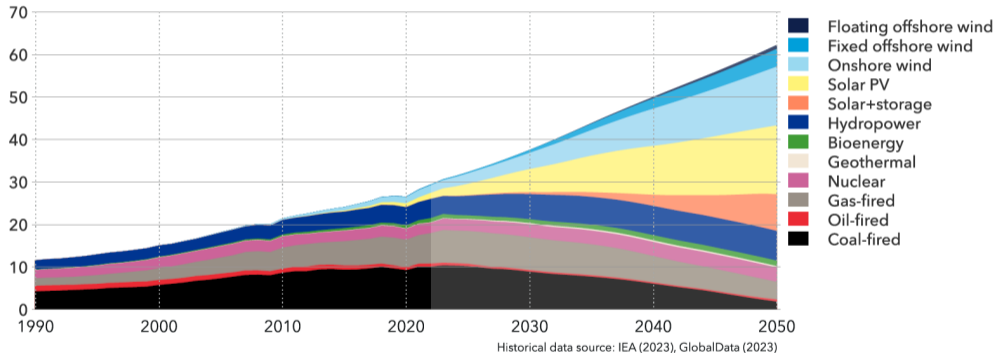

Figure courtesy of DNV©2024

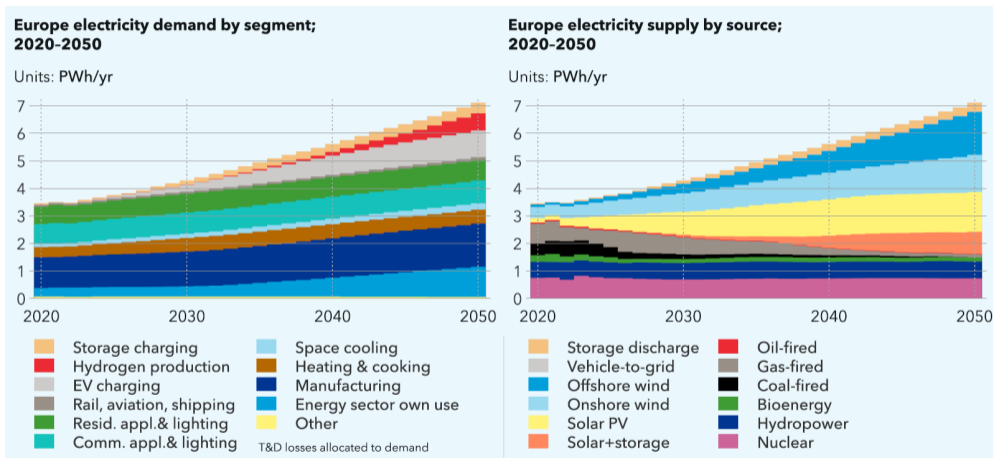

Figure courtesy of DNV©2024

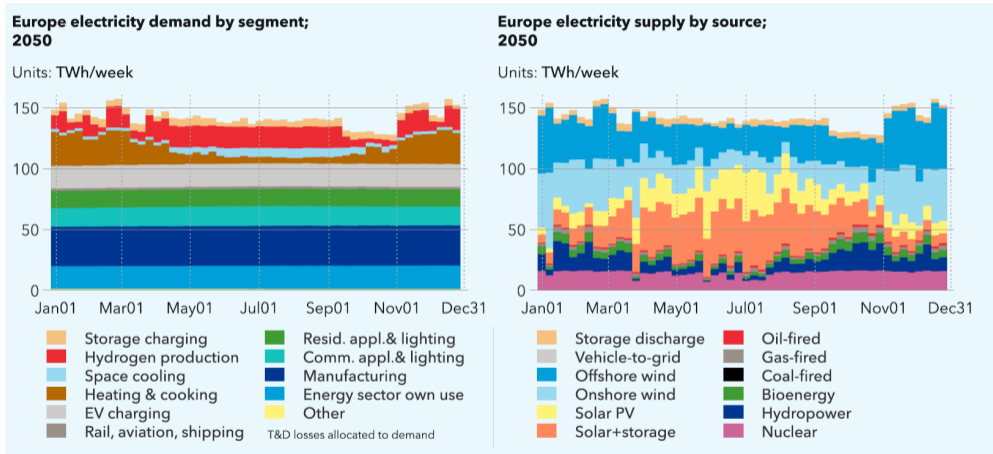
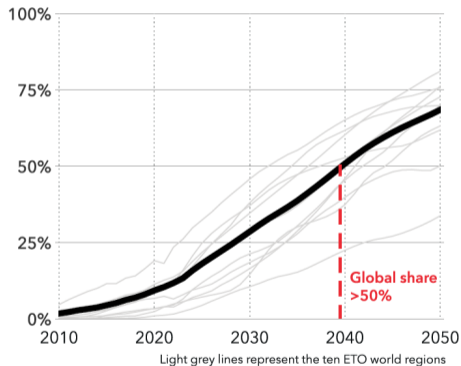

Figure courtesy of DNV©2024

## Share of solar and wind in global electricity generation

Units: Percentages



## Regional breakdown

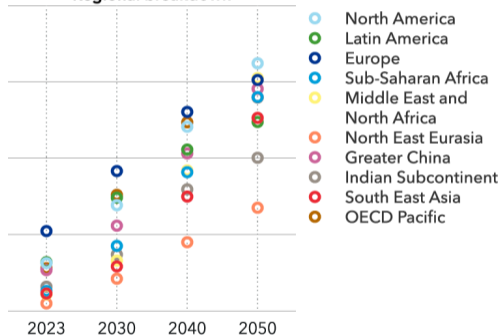

Figure courtesy of DNV©2024

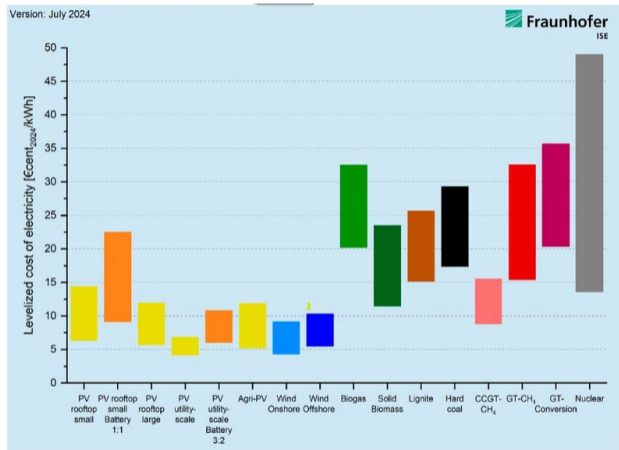

Figure courtesy of Power&Beyond.com ©2024



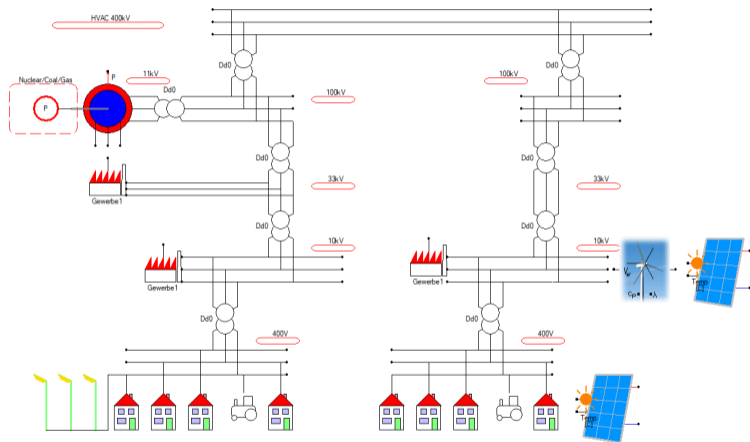

Figure courtesy of Caspoc©2024

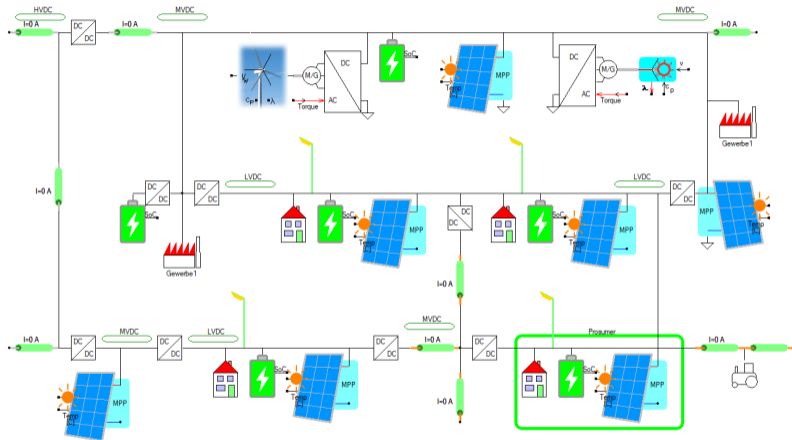

Figure courtesy of Caspoc©2024

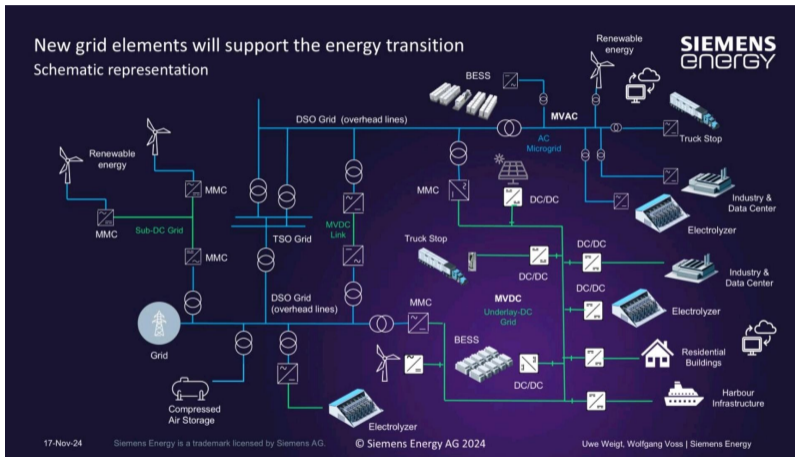

Figure courtesy of Siemens©2024

Verbruik, maar hoeveel en wanneer?

- Huishouden  
 $1\phi - 3kW(3MWh/yr) \dots 3\phi - 10kW(10MWh/yr)$
- Office  
1kW per employee
- Industry  
> 100kW

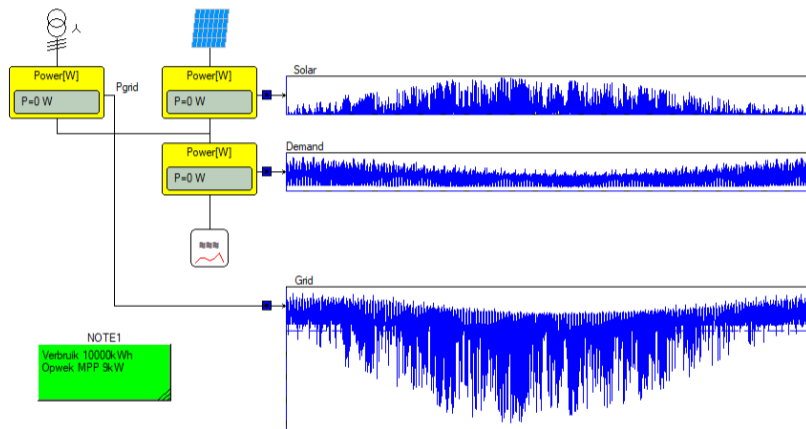
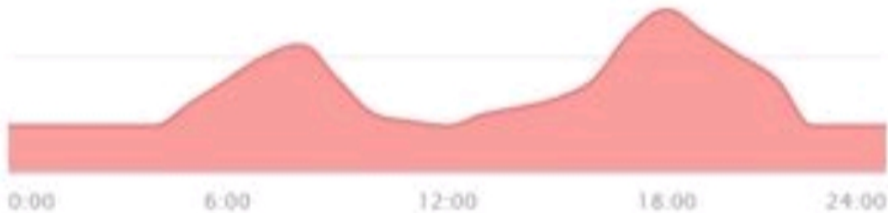

Figure courtesy of Caspoc©2024



# Schoolgaande kinderen



## Familie baby's + kleuters

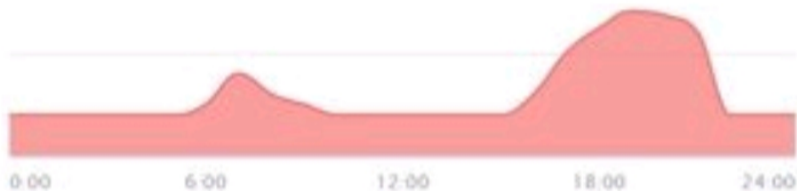

# Huishouden 1 of 2 personen





Gepensioneerd/thuiswerkend



# Nachtgerichte consumptie

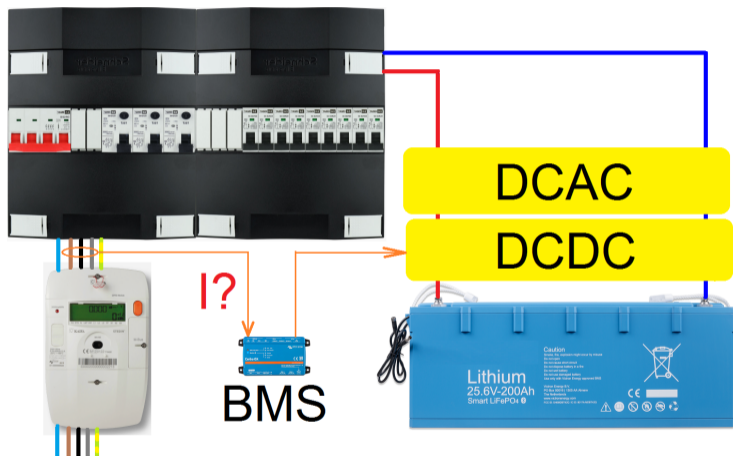

Figure courtesy of Caspoc©2024

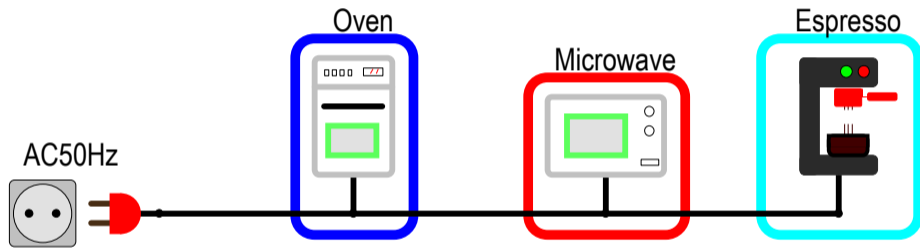

Figure courtesy of Caspoc©2024

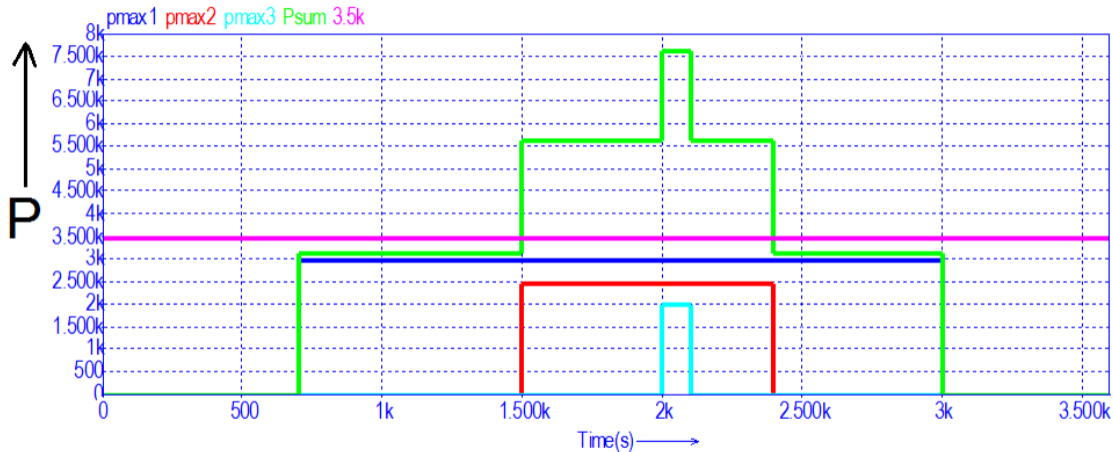

Figure courtesy of Caspoc©2024

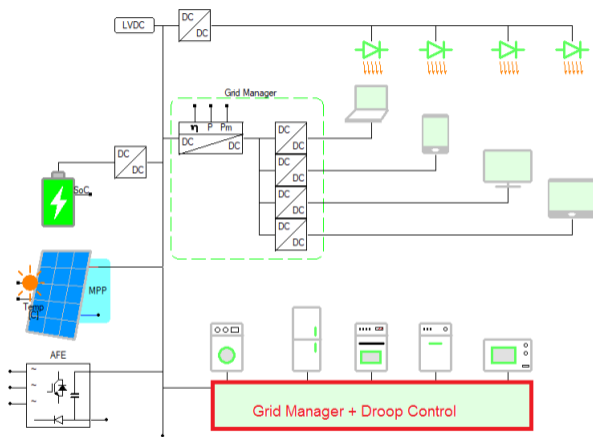

Figure courtesy of Caspoc©2024

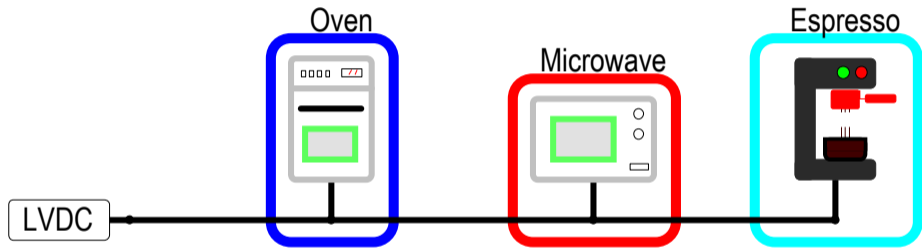

Figure courtesy of Caspoc©2024

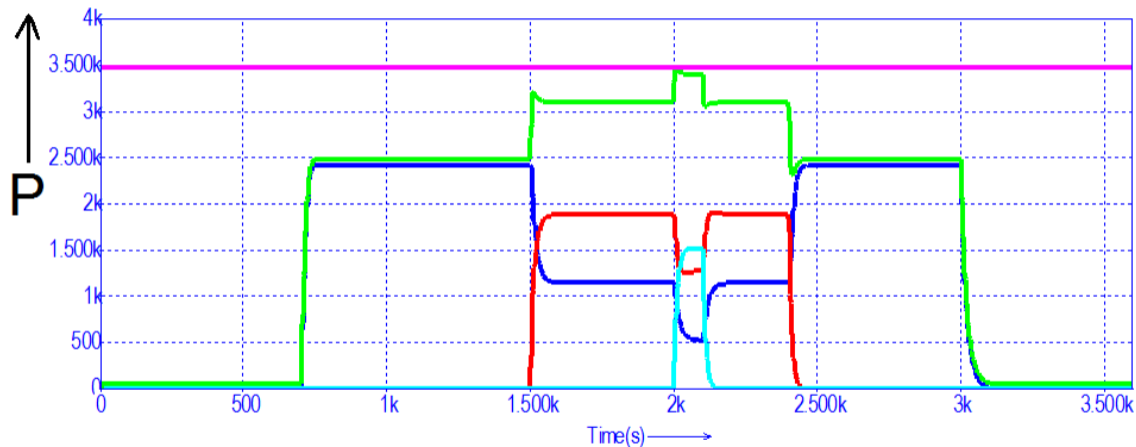

Figure courtesy of Caspoc©2024





**Heb jij het  
Beste Idee  
van Nederland?**  
**Doe mee**  
met de voorregistratie  
**en win!**

Figure courtesy of Kubr©2024

- Verschuiving richting opwek Solar en Wind
- Matchen vraag en aanbod?
- Meterkast van de toekomst

Thank you!

[www.caspoc.com](http://www.caspoc.com)

[P.vanDuijsen@caspoc.com](mailto:P.vanDuijsen@caspoc.com)

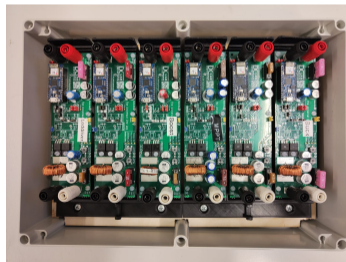

Figure courtesy of dc-lab.org©2024