

DC Grid Workshop

Prof. dr. ir. P.J. van Duijsen

The Hague University of Applied Sciences

Power Electronics & Energy Storage Event, June 27, 2023

THE HAGUE
UNIVERSITY OF
APPLIED SCIENCES



CaspoC



Power Electronics & Energy Storage event
28 mei 2024 | 1931 Congrescentrum 's-Hertogenbosch

ENERGY STORAGE



Contents

- DC grid structure
- Control
- Switching
- Protection
- Stability

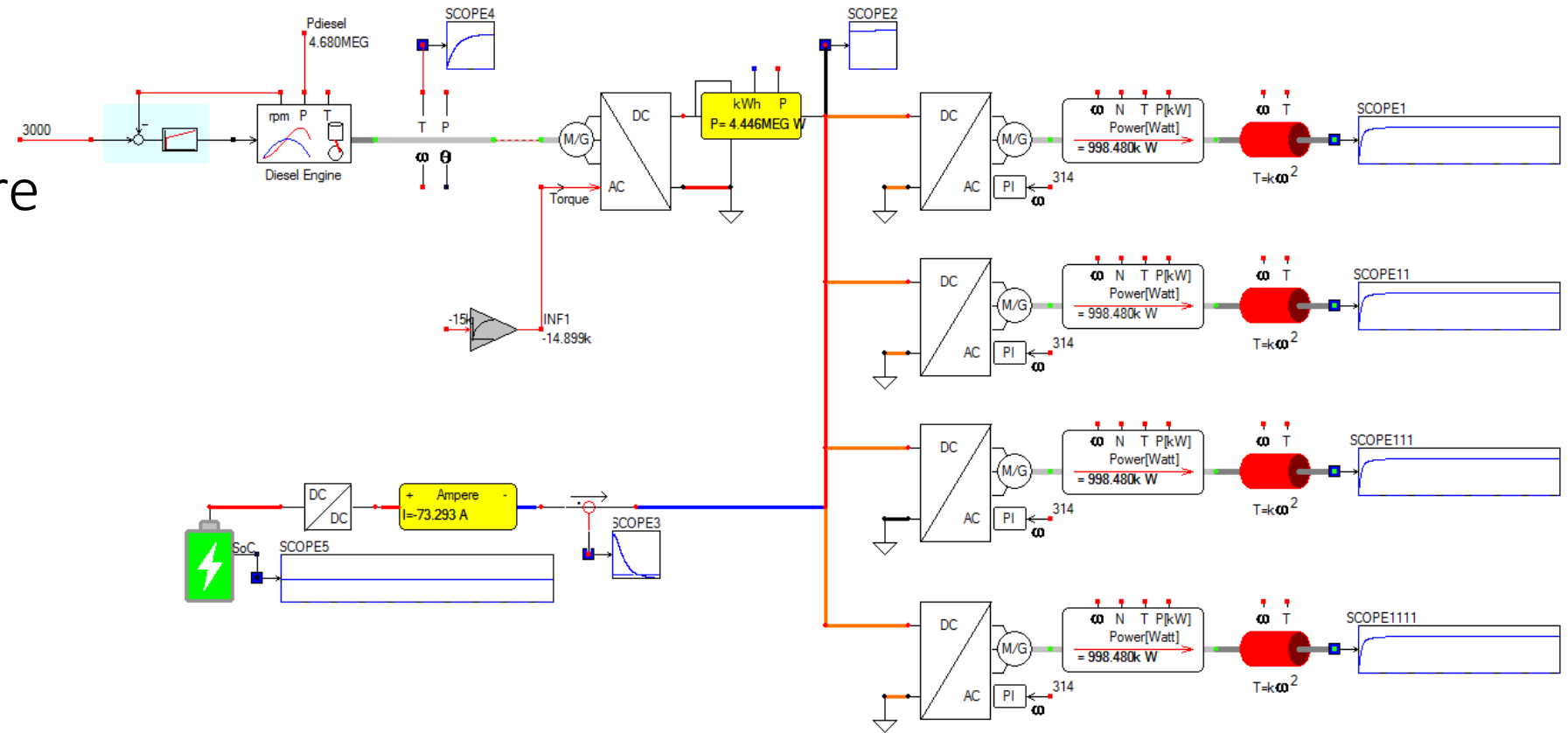

www.caspoc.com/tools



DC grid structure?

Structure of the DC Grid

Why do we need a DC Grid?

Lower losses is not the reason why we choose DC!

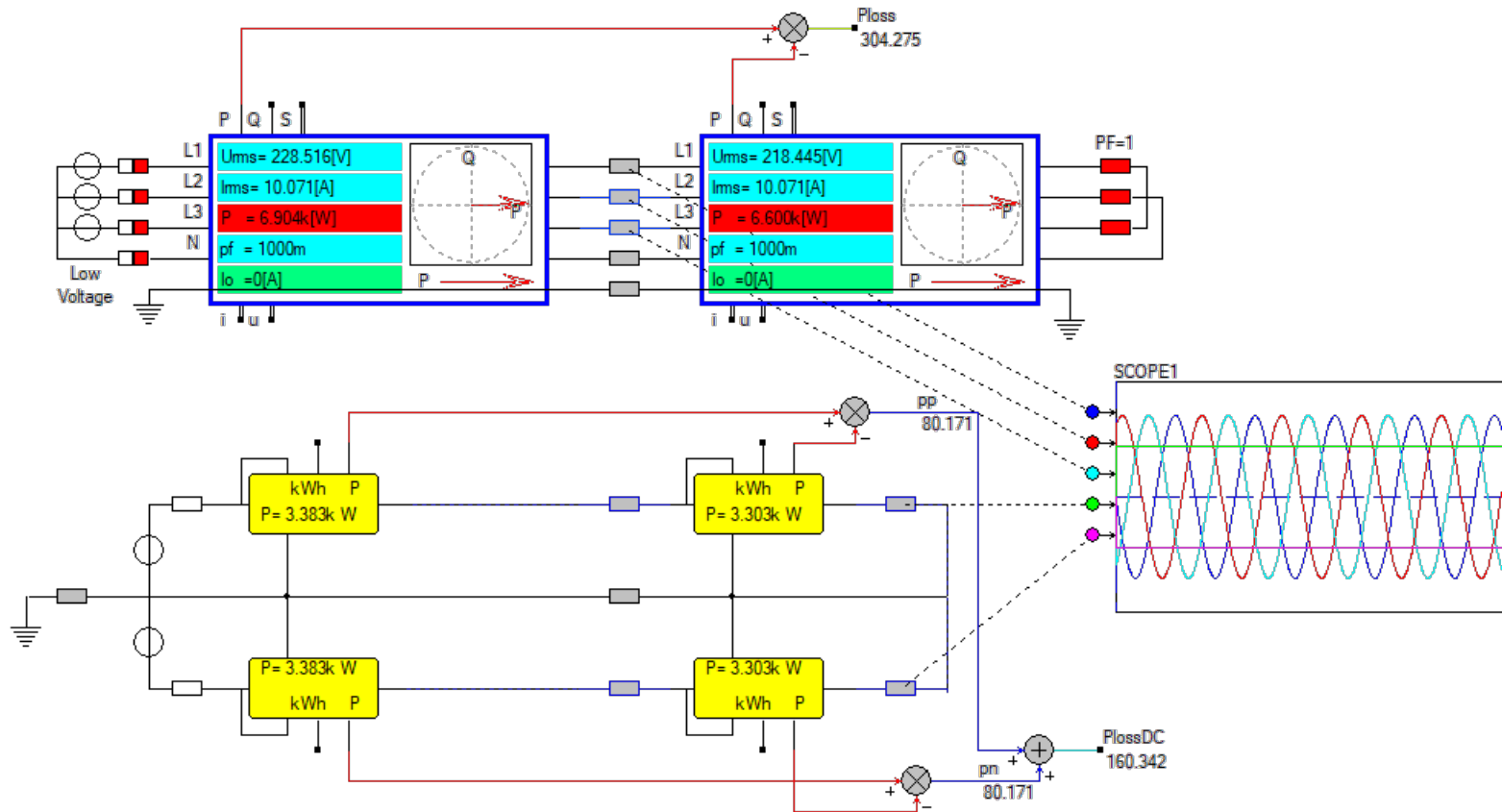

It is not about optimizing components It is optimizing the system!

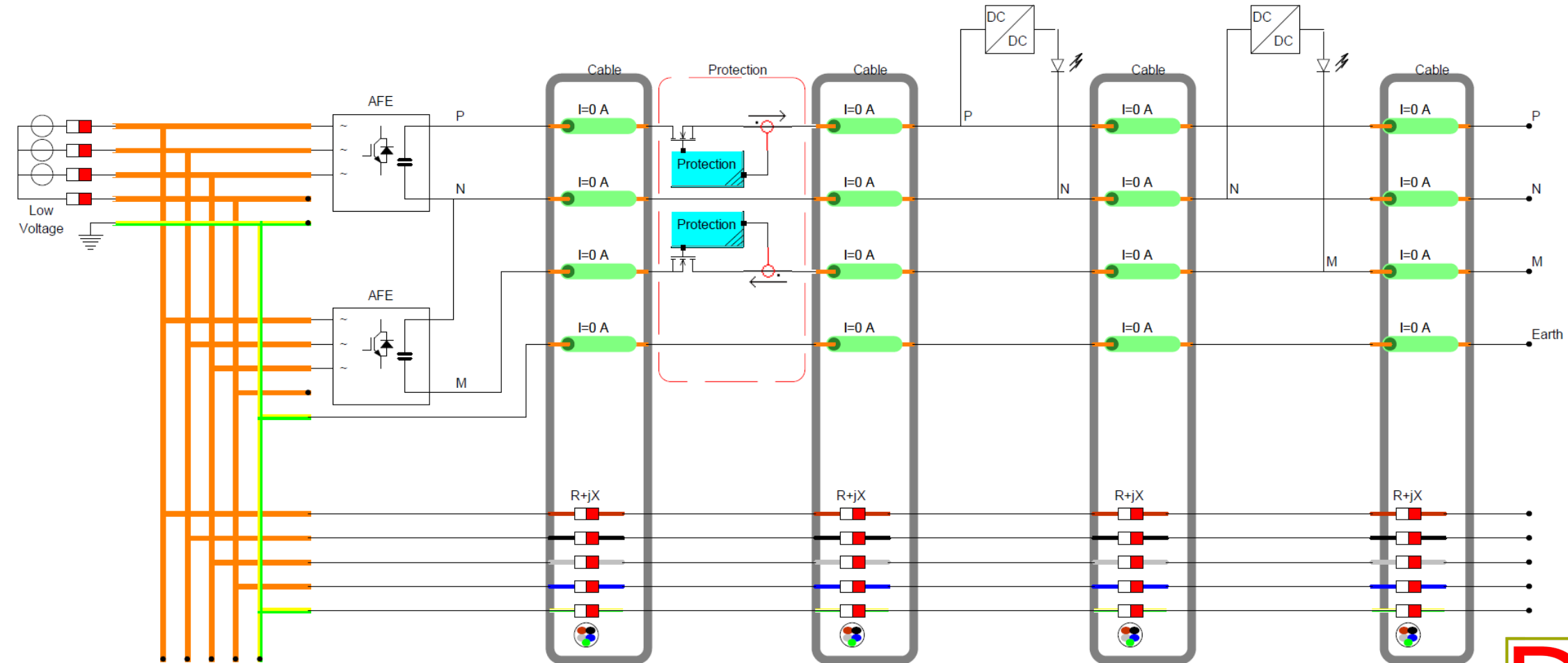

Which grid to choose?

- Centralized
- Decentralized

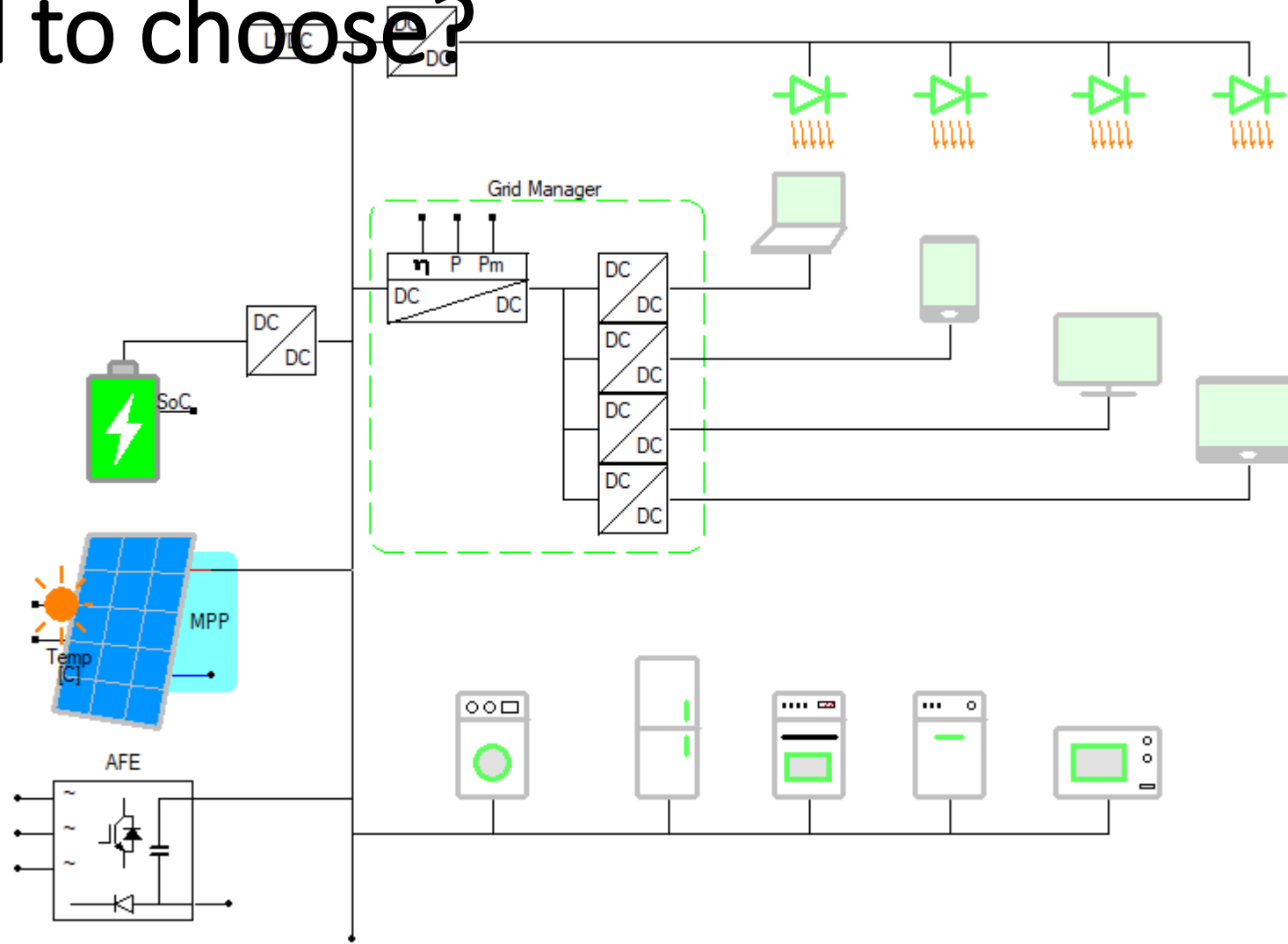

Centralized DC Grid with Grid Manager

- All control in one device
- Control of Power
- Breaker
- Inrush limiter

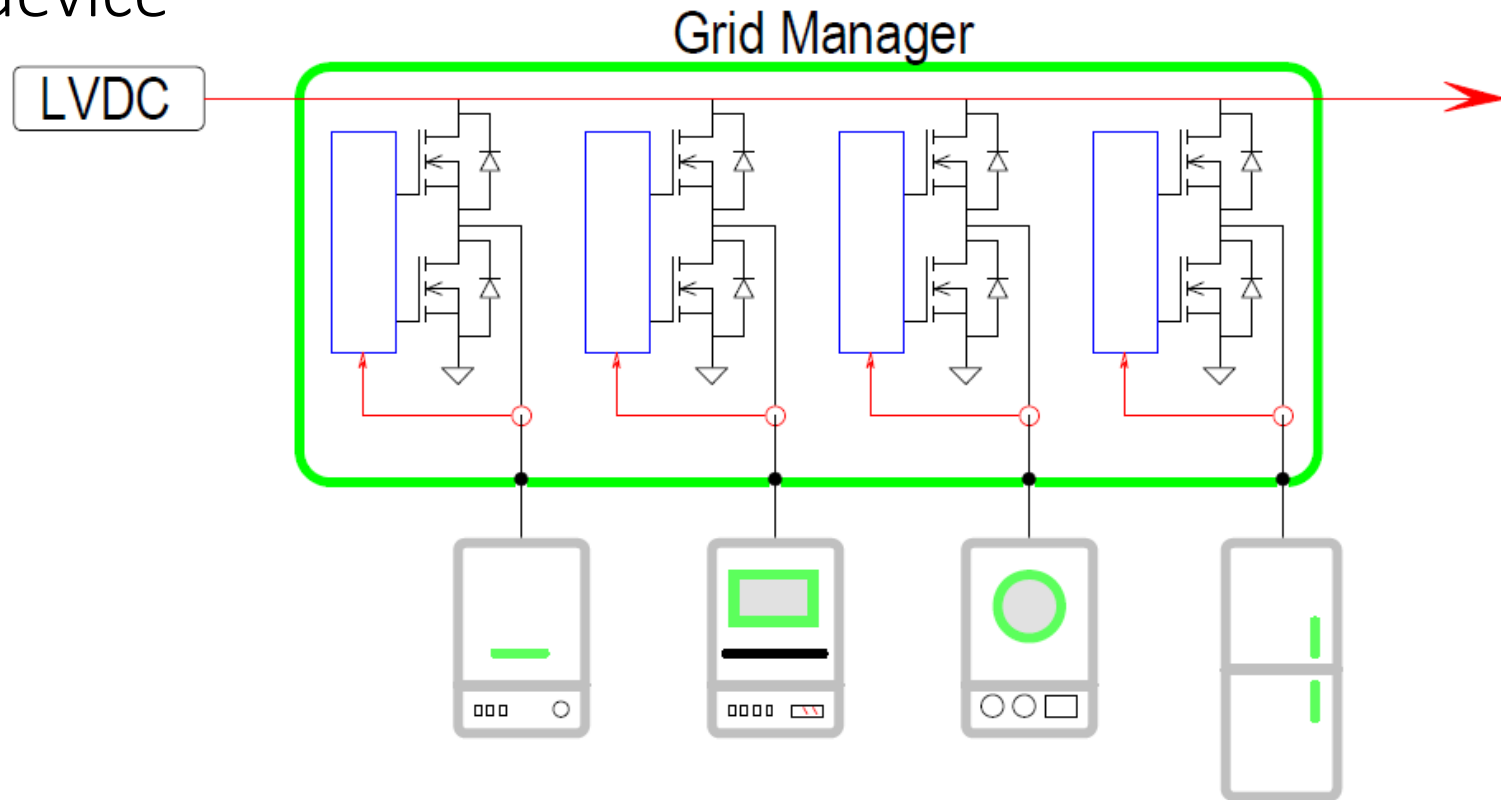

Decentralized DC Grid with Droop Control

- Droop control per appliance
- DCDC converter per appliance

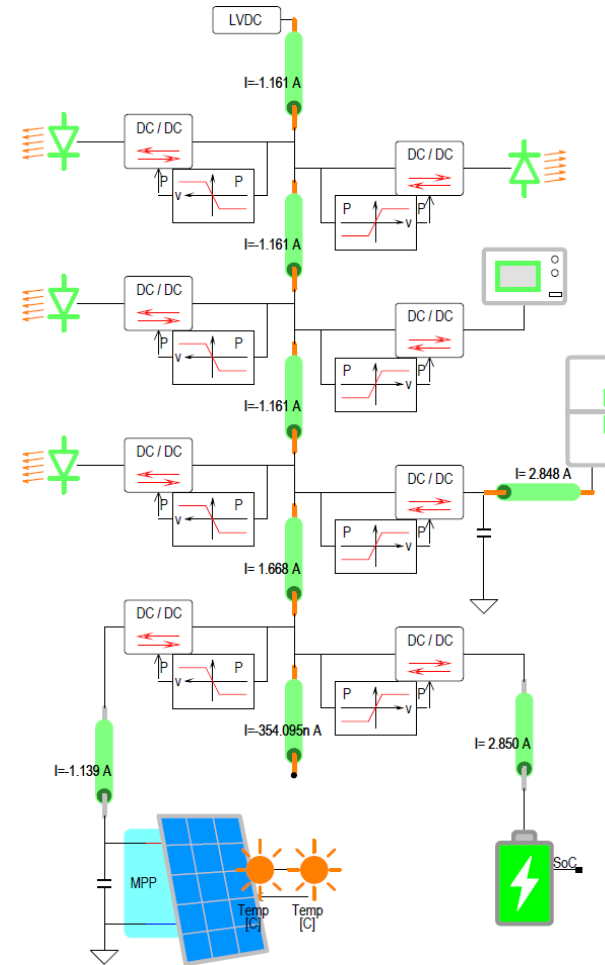

Producers and Consumers are directly coupled

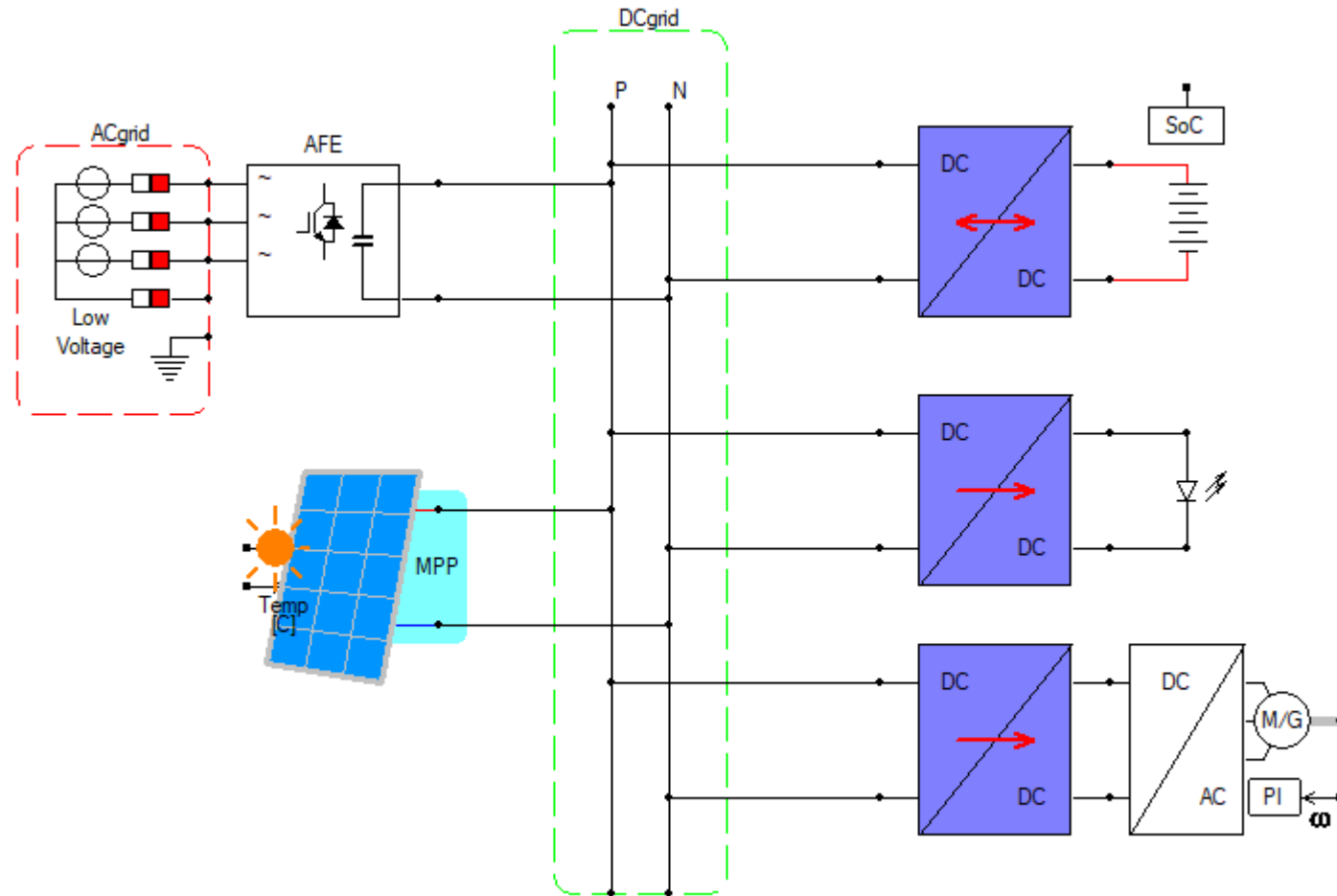

Exchange of Drive and Brake Energy

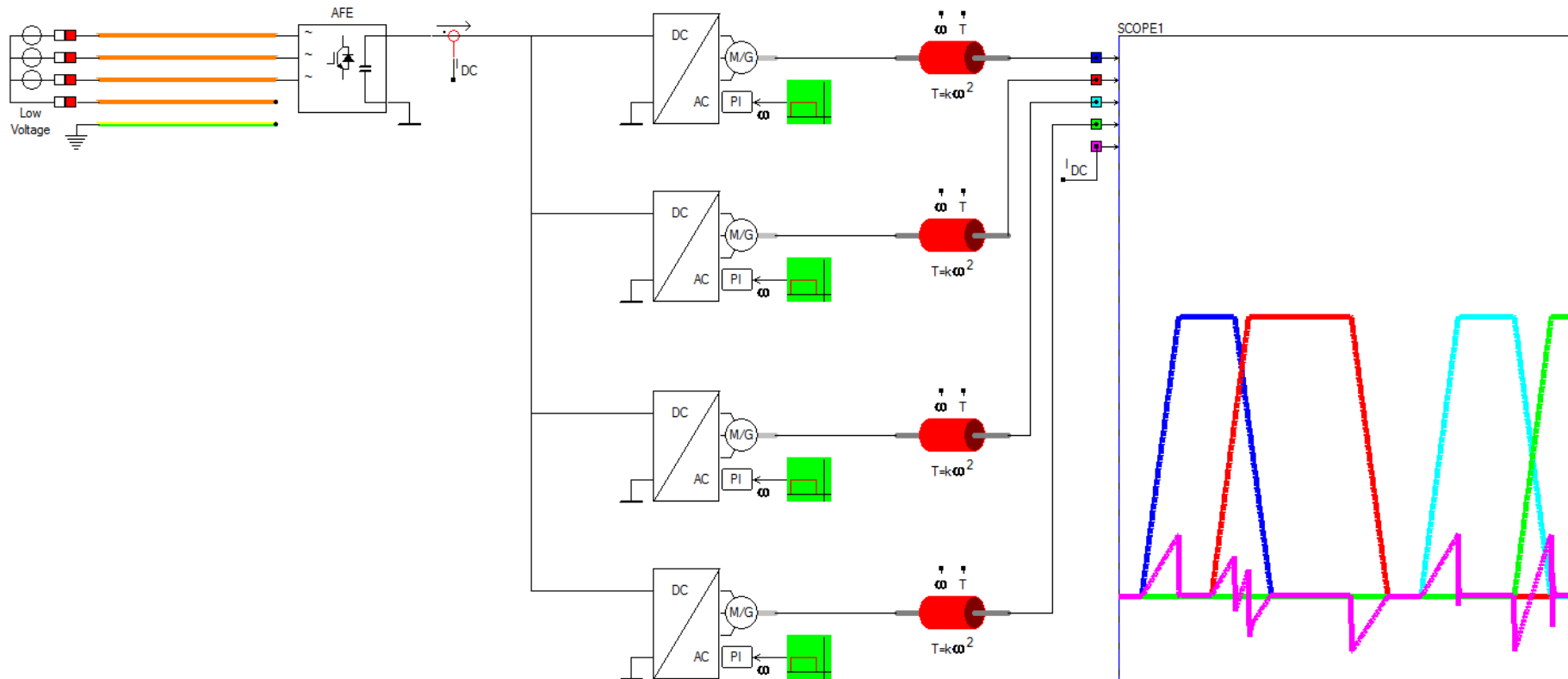

Ships connected to the DC grid

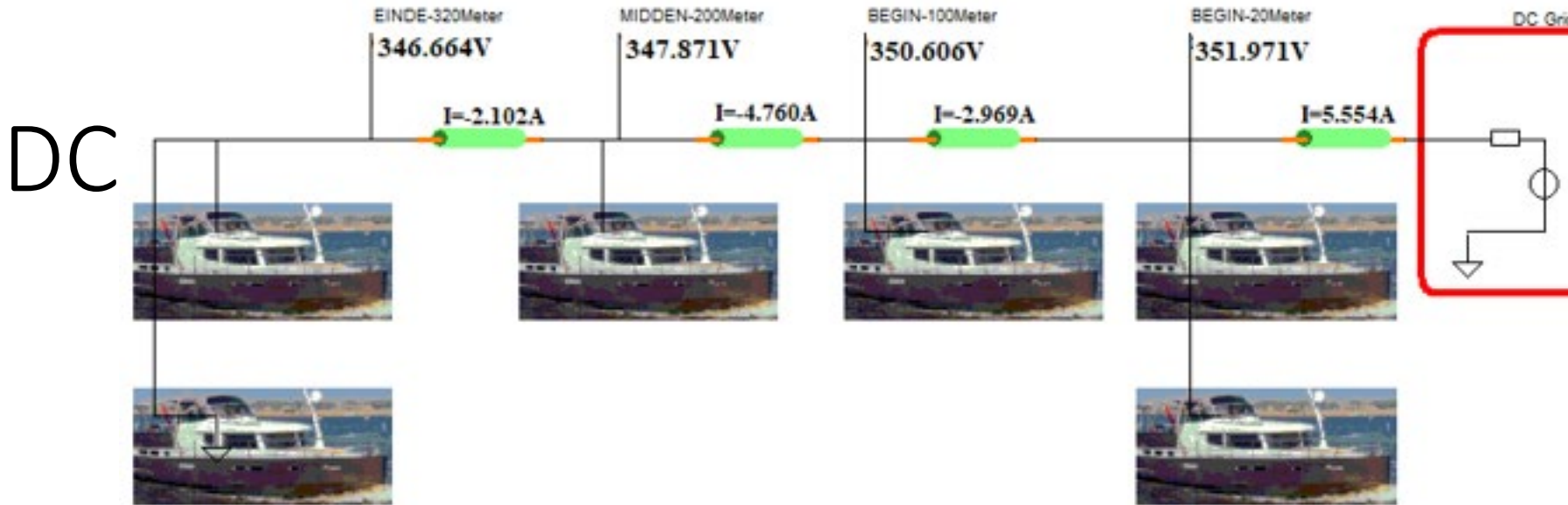

DC Droop control per ship

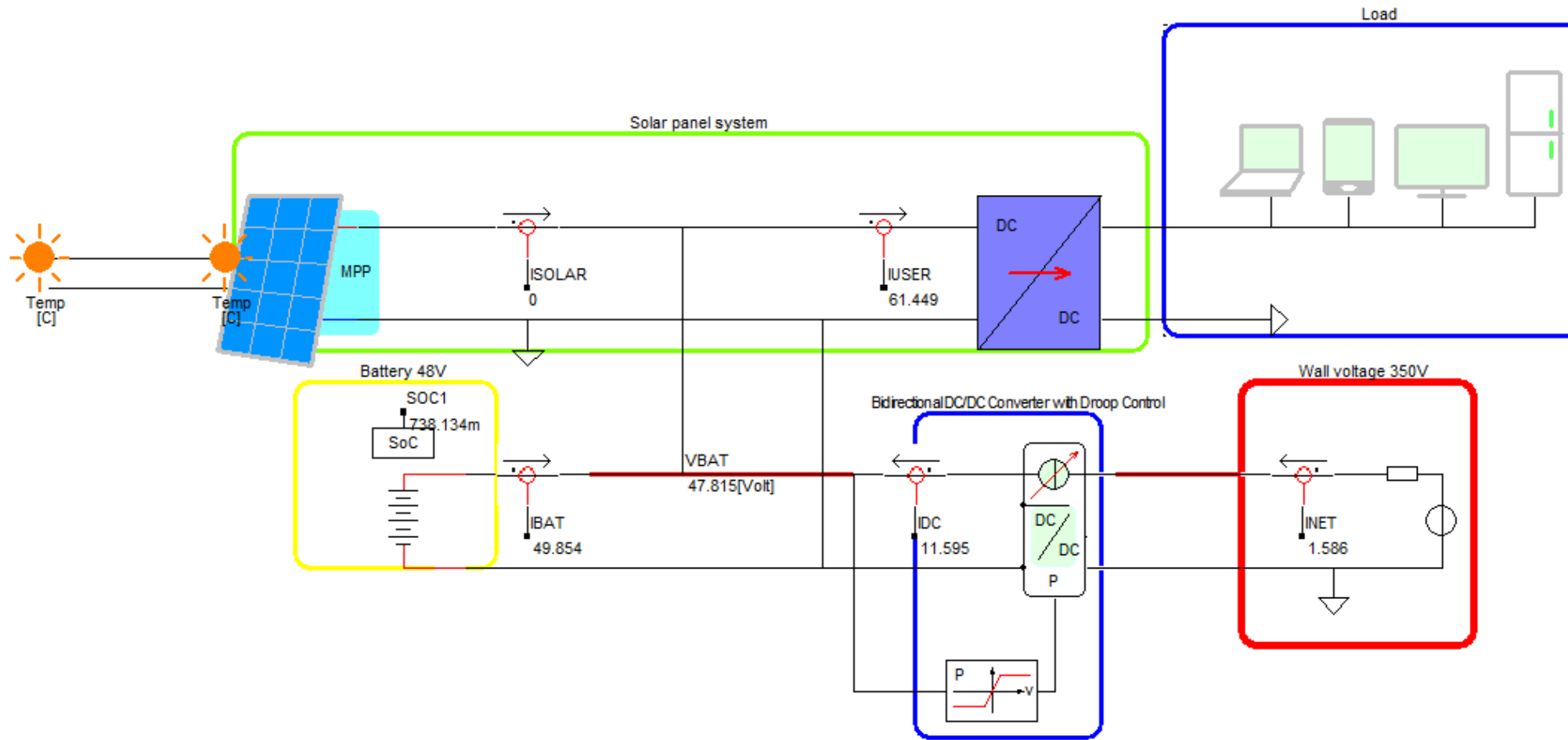

Switching in the DC grid?

What type of switches do exist,
if they do exist at all?

Grid Manager contains multiple Synchronous Buck Converters

- power flow
- Current Limited
- Breaker
- Non-Isolated

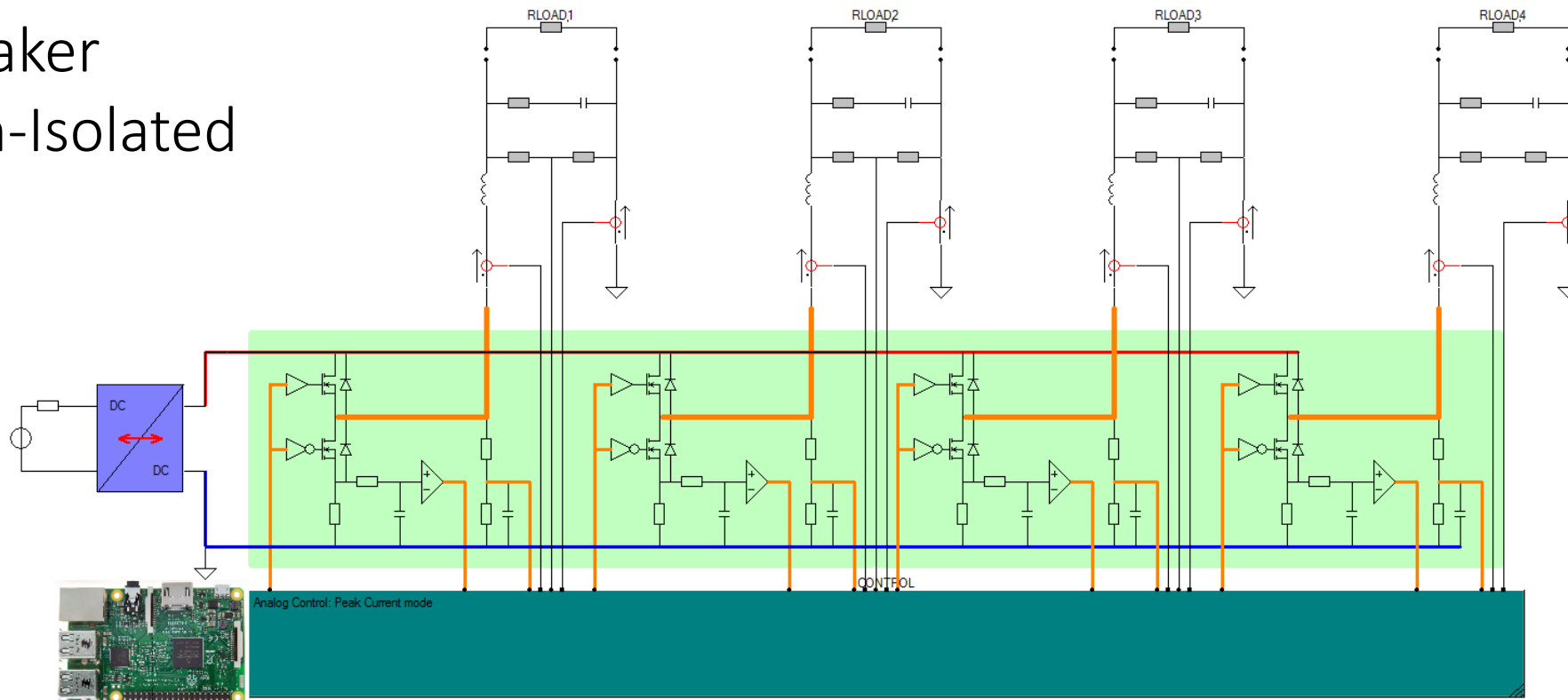

Dual Active Bridge is Isolated

- Bidirectional power flow
- Current Limited
- Breaker
- Isolated
- DC transformer

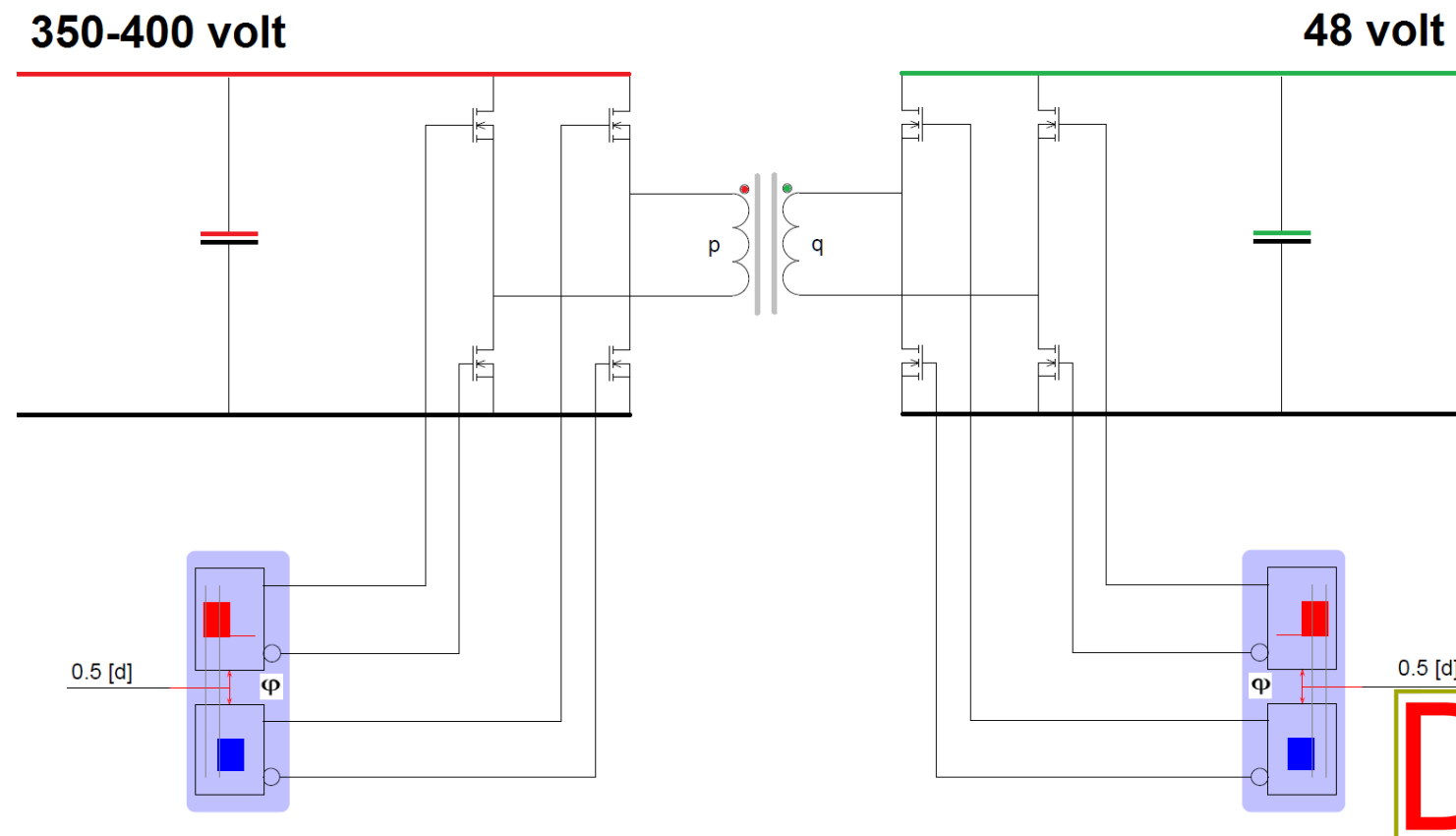

Connecting two DC grids with different voltage levels

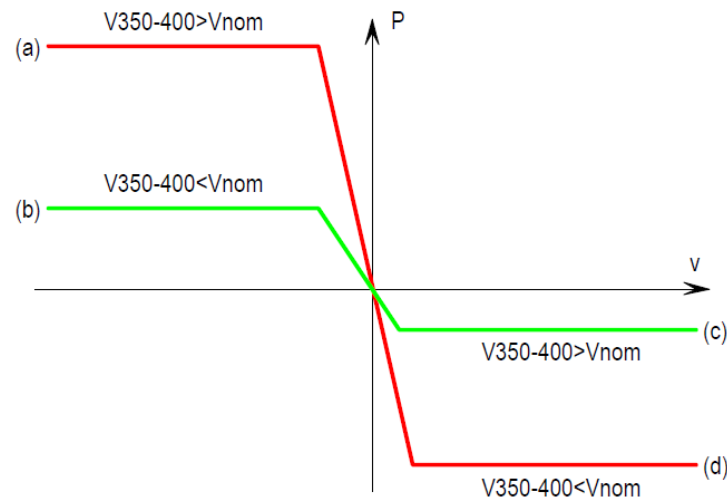
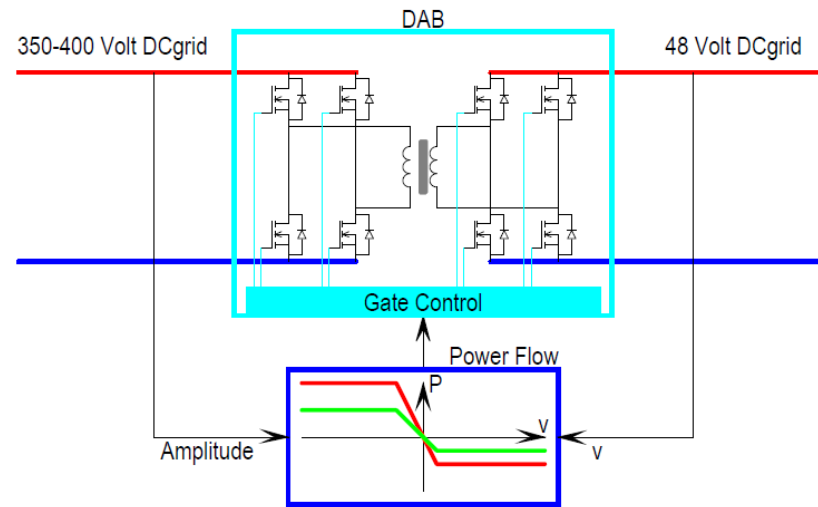

DC grid control?

Control and Power Congestion Management
in the DC Grid



Control the current in a Meshed grid

- Nodal voltage defines current flow
- DCDC converters have losses

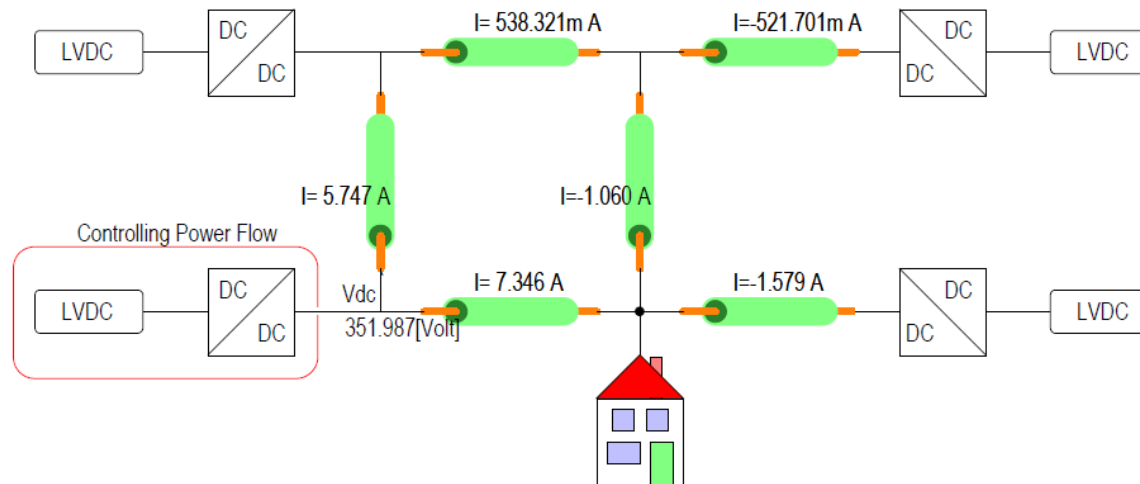
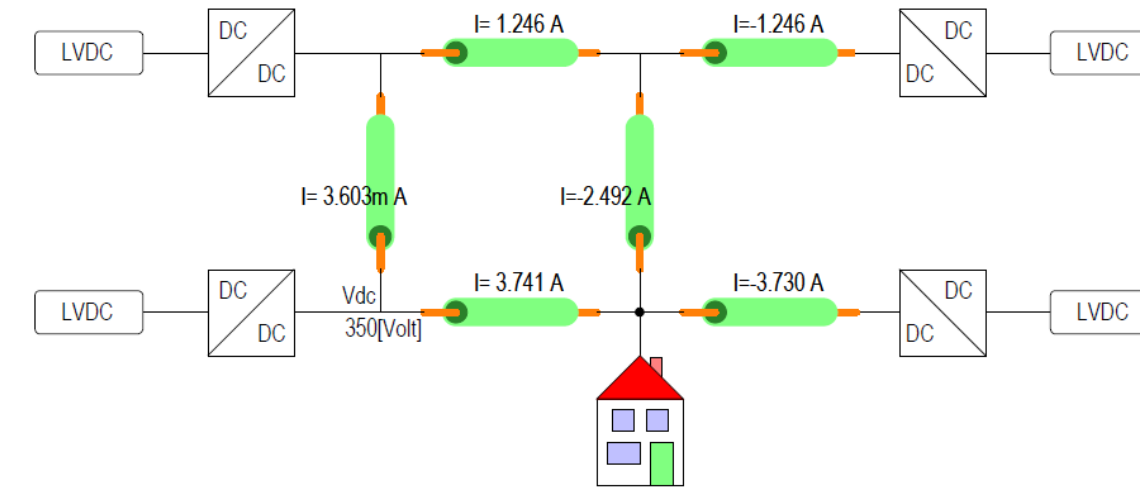

Drop Control regulates in a decentralized grid

- Controlled current flow per appliance
- Islanding operation
- No communication required

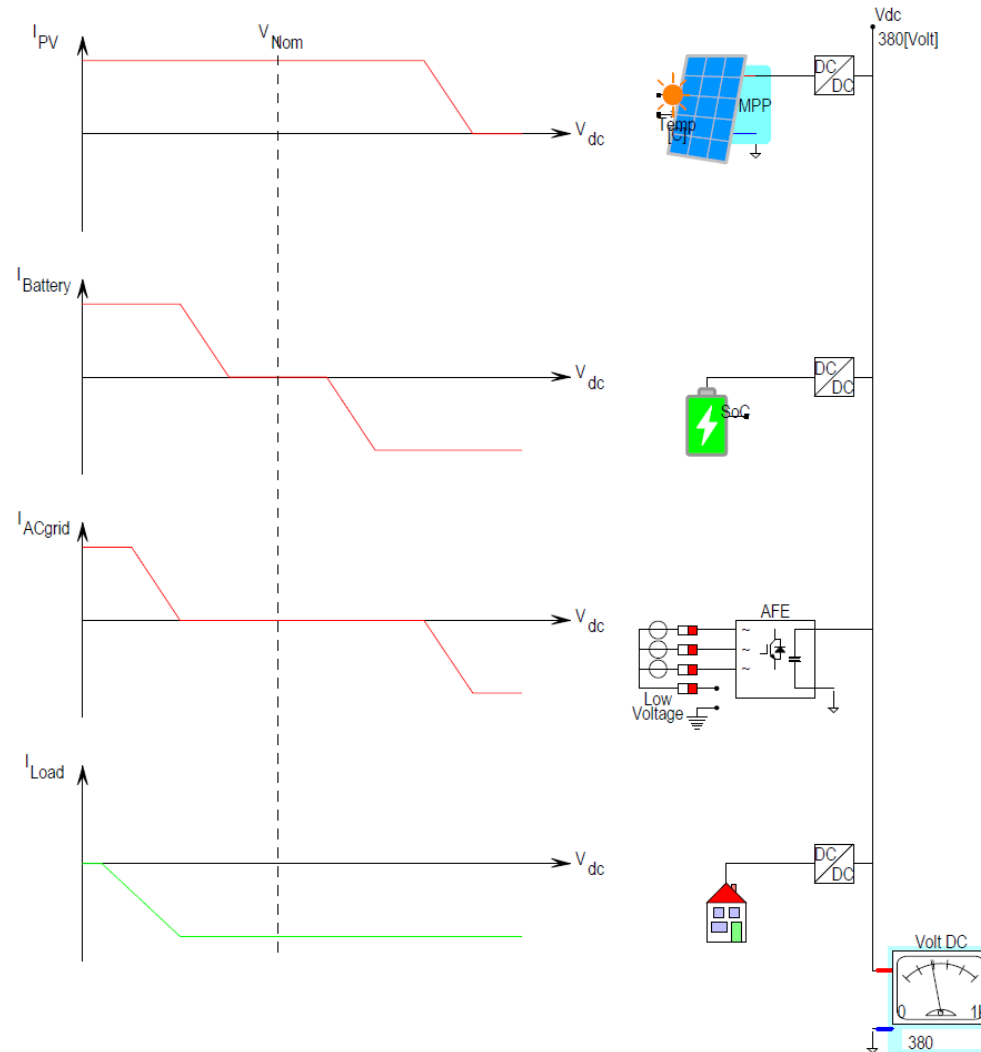

DC grid selectivity and protection?

Protection and/or selectivity
in the DC Grid?



When grounding, the DC grid has to be isolated from the AC grid

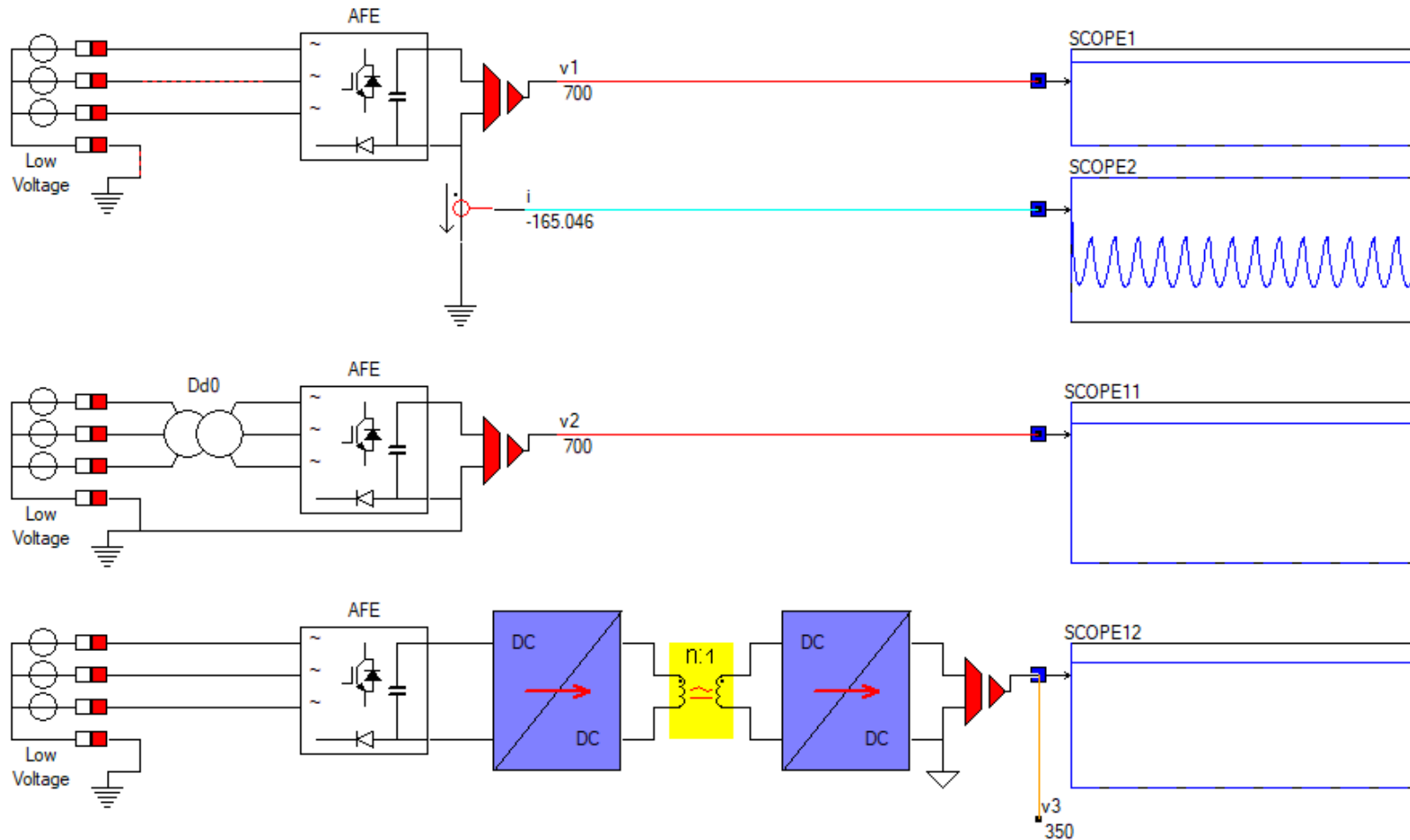

Grid system?

- You can choose an isolated Grid IT to implement earth leakage detection,
- but your grid is floating!

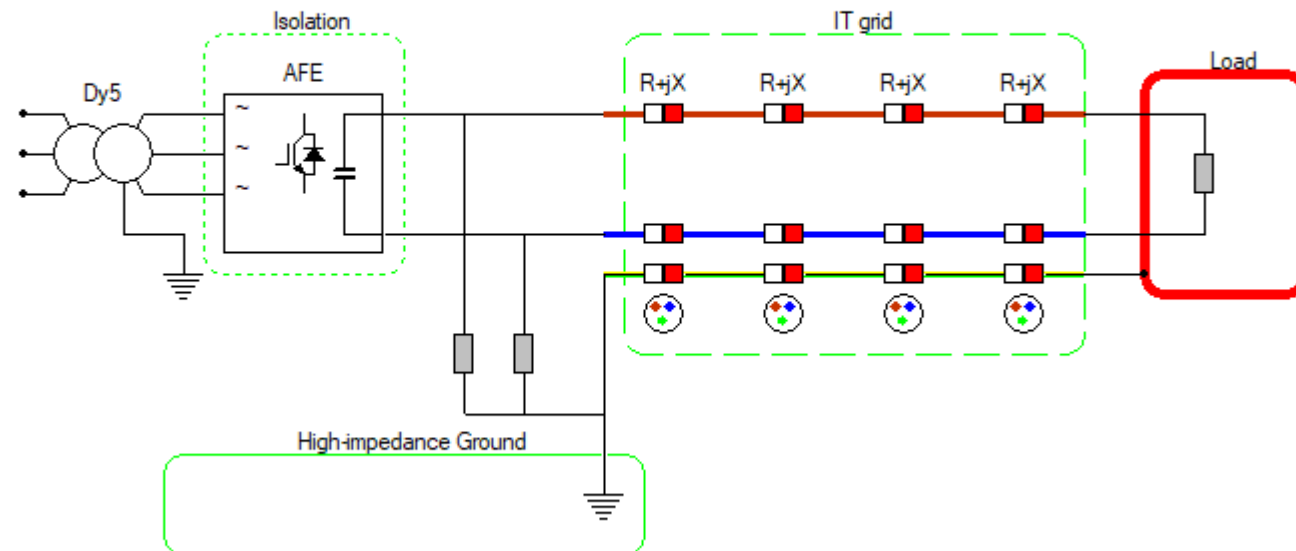

Fuse?

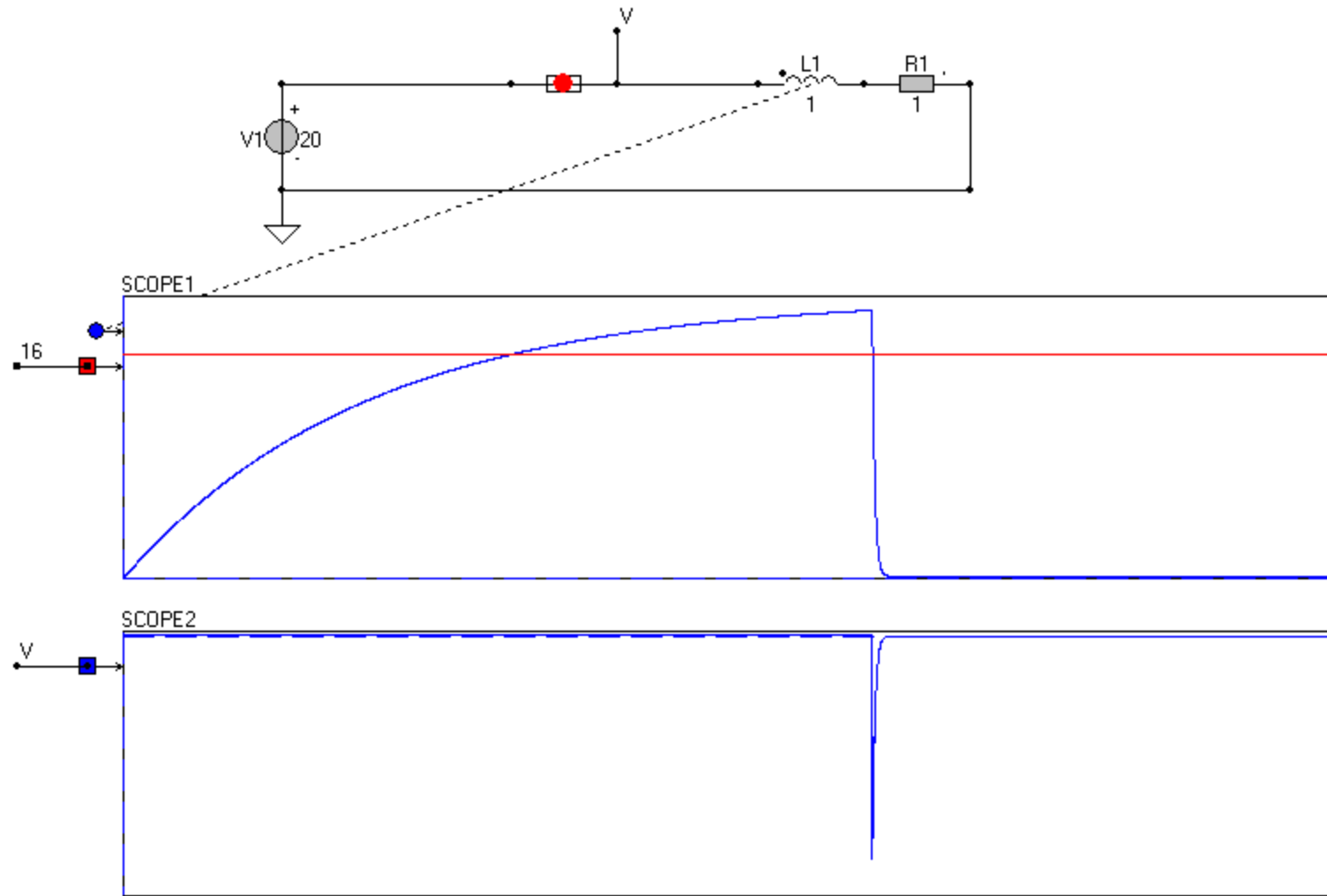

Fuse?

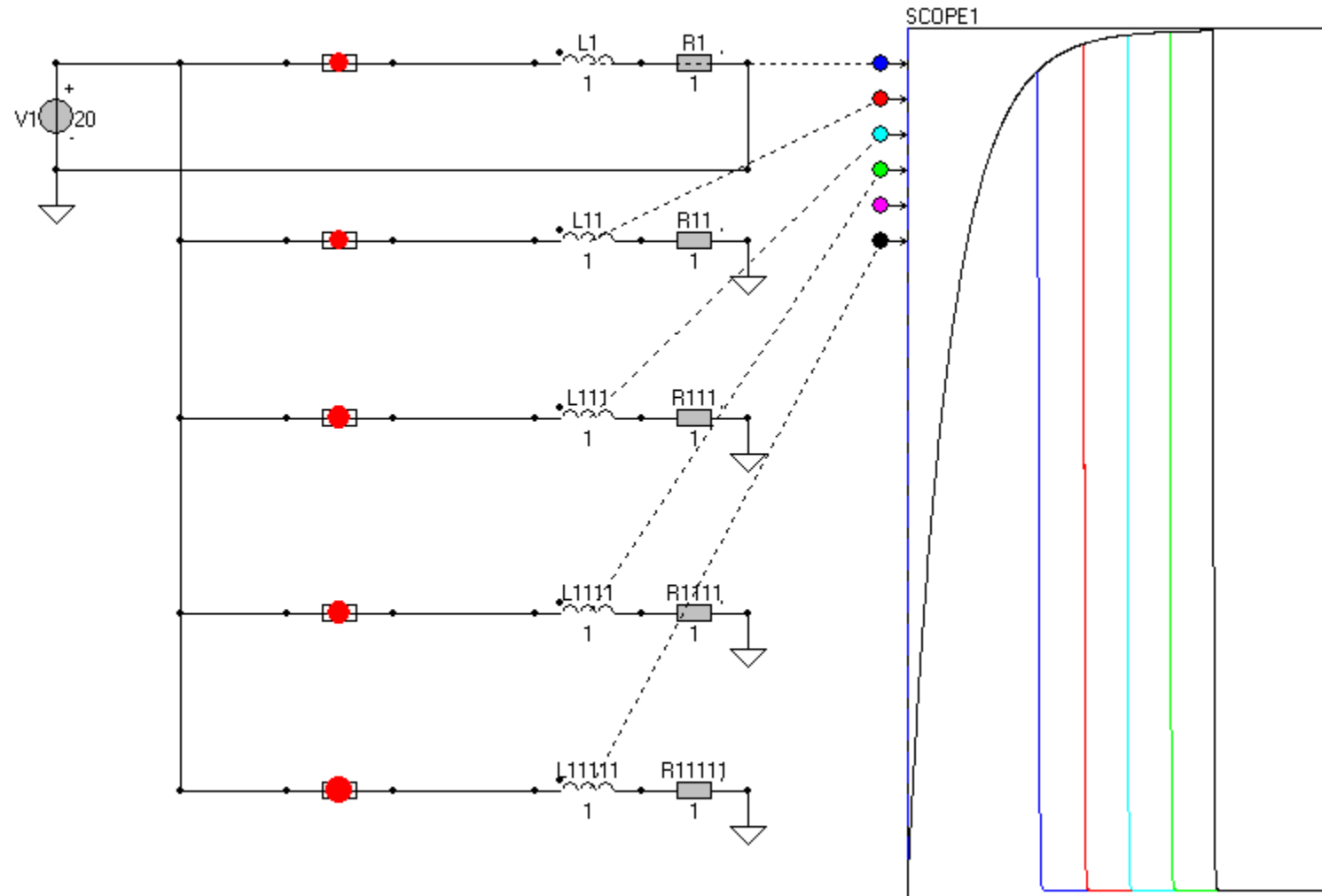

RoCoC Rate of Change of Current

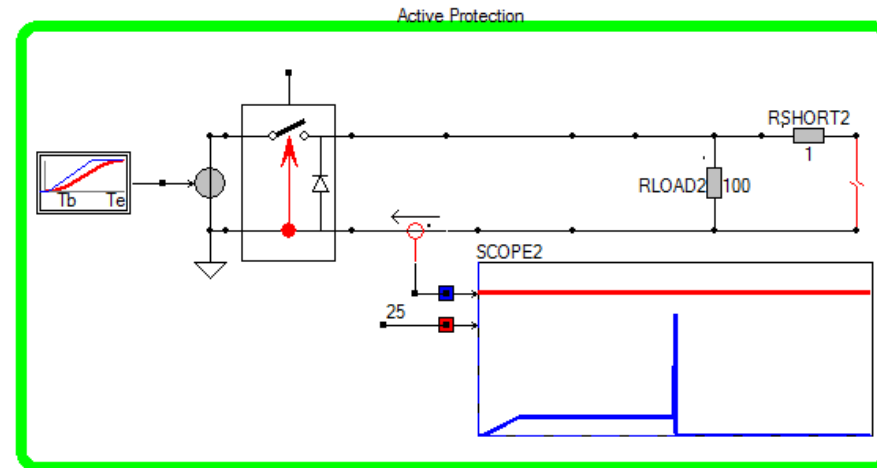
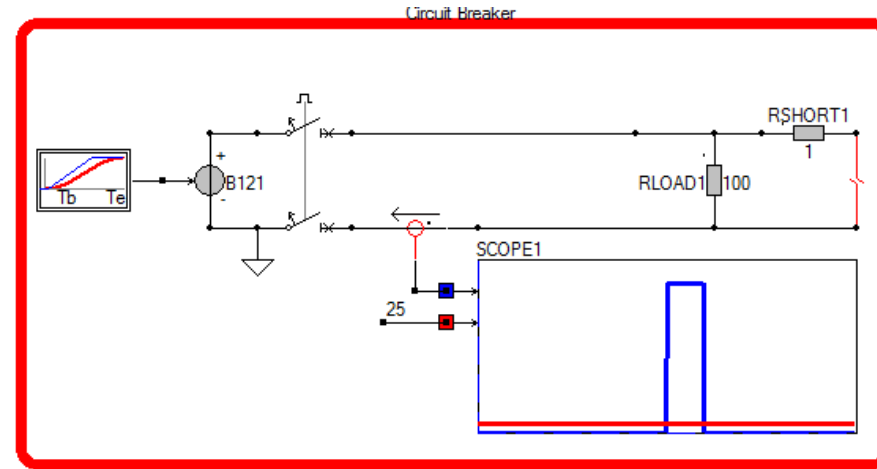

DC grid stability?

How to predict and ensure stability in the
DC Grid



Static stability depends in Droop Control Characteristics

- Droop characteristic
- per appliance
- Low Bandwidth
- Stand alone operation

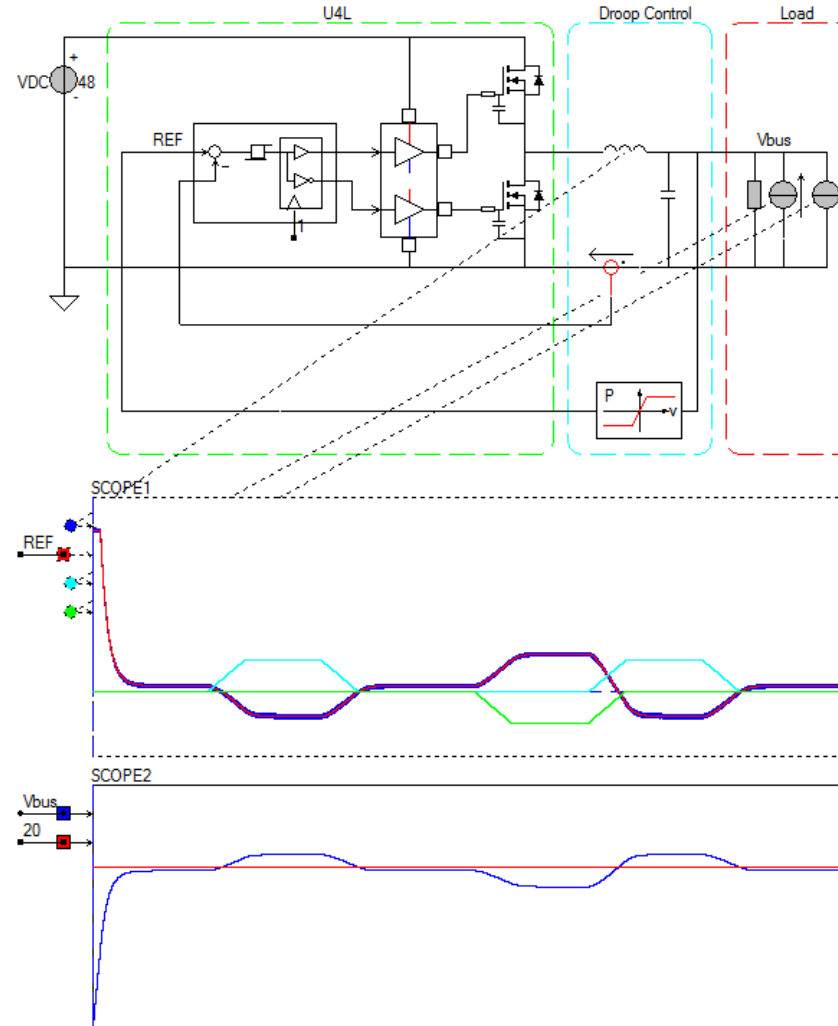

Dynamic stability depends on input and output impedance

- $Z_{out} < Z_{in}$
- Middlebrooks Stability Criterion

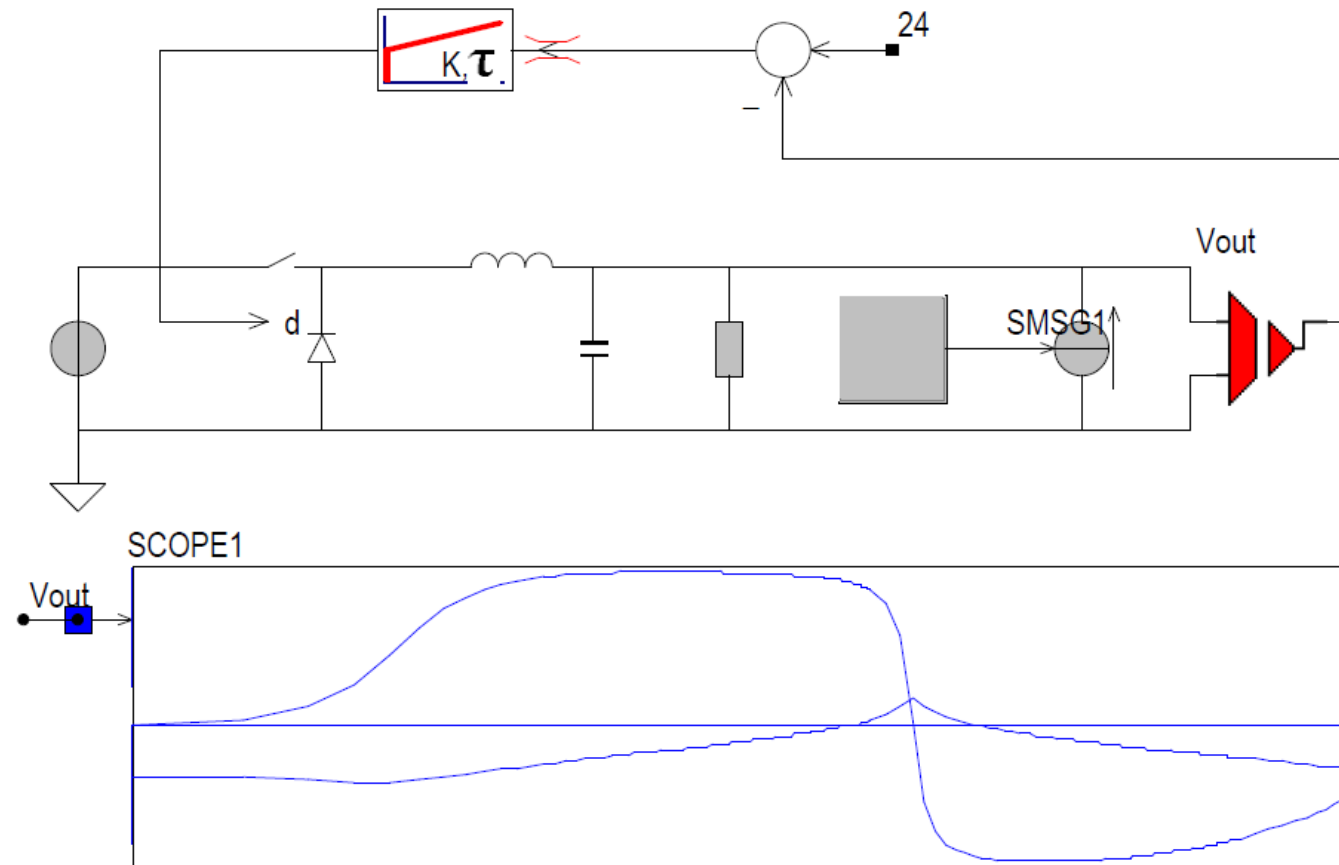

Conclusion: DC Grid: Protect or Control?

- Centralized or Decentralized
- Control
- Protection
- Stability



www.caspoc.com/tools

Thanks for your attention!

www.dc-lab.org



Power Electronics & Energy Storage event
28 mei 2024 | 1931 Congrescentrum 's-Hertogenbosch

ENERGY STORAGE

